

-NOTES-

1. MAT'L: H. R. STEEL.
2. FINISH: HOT DIP GALVANIZE PER ASTM A153 (LATEST REV)

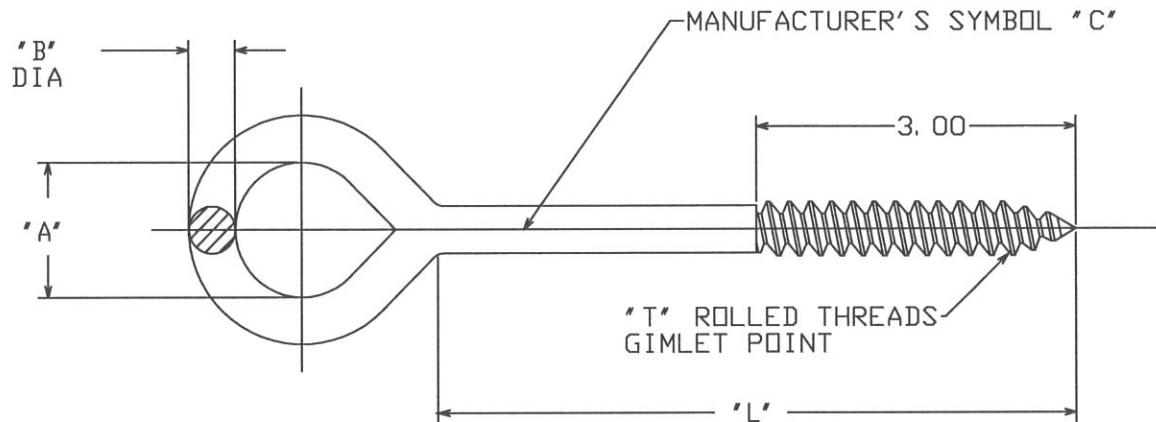

CAT. NO	DESCRIPTION	"A"	"B"	"C"	"L"	"T"
29930	SCREW EYE BOLT	1.25	.44	1.5	6	1/2-6
29931	SCREW EYE BOLT	1.5	.56	2	6.75	5/8-5
29932	SCREW EYE BOLT	1.5	.63	2	6.75	3/4-5
C205-0094	SCREW EYE BOLT	1.25	.44	1.5	4	1/2-6

CHANCE TOLERANCE CHART		HUBBELL POWER SYSTEMS	
CONFIDENTIAL: THIS DRAWING AND ITS CONTENTS ARE CONFIDENTIAL AND THE EXCLUSIVE PROPERTY OF HUBBELL POWER SYSTEMS. NO PUBLICATION, DISTRIBUTION OR COPIES MAY BE MADE WITHOUT THE WRITTEN CONSENT OF HUBBELL POWER SYSTEMS. UNPUBLISHED. ALL RIGHTS RESERVED UNDER THE COPYRIGHT LAWS.			
TITLE SCREW EYE BOLT		SIZE DWG NO. SB SA29930	CAT / PART / ASSY NO. SEE CHART
DO NOT SCALE THIS DRAWING	DRN BY WILSON	DATE 07/09/97	SHEET 1 OF 1